

## INDUCTION MOTOR

### 6W

### □ 60mm

### LEAD WIRE TYPE TERMINAL BOX TYPE

K6IS6N□



K6IS6N□-T



### SPECIFICATIONS

6W continuous rating, four poles

Model	Voltage (V)	Frequency (Hz)	Current (A)	Start T. (N·m/Kgf·Cm)	Rated T. (N·m/Kgf·Cm)	Speed (rpm)	Condenser (μF)
K6I□6NJ(-T)	100	50	0,25	0,04/0,4	0,049/0,49	1200	3
		60	0,23			1500	
K6I□6NU(-T)	110	60	0,18	0,035/0,35	0,04/0,4	1500	2
	115		0,19	0,04/0,4			
K6I□6NL(-T)	200	50	0,11	0,045/0,45	0,049/0,49	1200	0,8
		60				0,04/0,4	
K6I□6NC(-T)	220	50	0,11	0,04/0,4	0,047/0,47	1250	0,6
		60	0,1	0,035/0,35	0,04/0,4	1500	
	230	50	0,12	0,045/0,45	0,047/0,47	1250	
		60	0,11	0,04/0,4	0,04/0,4	1500	
K6I□6ND(-T)	240	50	0,12	0,045/0,45	0,047/0,47	1250	0,5

\* □ : SHAFT SHAPE (S : STRAIGHT, G : PINION)

### RATED TORQUE OF GEARHEAD

#### ● 50Hz

unit = above : N·m / below : kgfcm

Model Motor/ Gearhead	Speed(rpm)	500	416	300	250	200	166	150	120	100	83	75	60	50	41	37	30	25	20	16	15	12,5	10	8,3	7,5	6
	Ratio	3	3,6	5	6	7,5	9	10	12,5	15	18	20	25	30	36	40	50	60	75	90	100	120	150	180	200	250
K6I□6N□(-T) K6G□B(C)	0,11	0,14	0,19	0,23	0,29	0,34	0,38	0,48	0,57	0,69	0,69	0,86	1,03	1,23	1,37	1,54	1,85	2,31	2,78	3	3	3	3	3	3	3
	1,1	1,4	1,9	2,3	2,9	3,4	3,8	4,8	5,7	6,9	6,9	8,6	10,3	12,3	13,7	15,4	18,5	23,1	27,8	30	30	30	30	30	30	30

#### ● 60Hz

unit = above : N·m / below : kgfcm

Model Motor/ Gearhead	Speed(rpm)	600	500	360	300	240	200	180	144	120	100	90	72	60	50	45	36	30	24	20	18	15	12	10	9	7,2
	Ratio	3	3,6	5	6	7,5	9	10	12,5	15	18	20	25	30	36	40	50	60	75	90	100	120	150	180	200	250
K6I□6N□(-T) K6G□B(C)	0,10	0,12	0,16	1,19	0,24	0,29	0,32	0,41	0,49	0,58	0,58	0,73	0,87	1,05	1,17	1,31	1,57	1,97	2,36	2,62	3	3	3	3	3	3
	1,0	1,2	1,6	1,9	2,4	2,9	3,2	4,1	4,9	5,8	5,8	7,3	8,7	10,5	11,7	13,1	15,7	19,7	23,6	26,2	30	30	30	30	30	30

\* Gearhead and decimal gearhead are sold separately.

\* The code in □ of gearhead model is for gear ratio.

\*   color indicates that the output shaft of the geared motor rotates in the same direction as the output shaft of the motor. Others indicate rotation in the opposite direction.

\* If you are to have less ratio than the ratio in the table, you can install the decimal gearhead, which has one tenth of the ratio, between the gearhead and the motor. In this case, the permissible torque is 3N·m/30kgfcm.

\* RPM is based on motor's synchronous rpm (50HZ:1500rpm, 60HZ:1800rpm) and calculated by dividing gear ratio. Actual rpm is 2~20% less than indicating rpm according to load size.

## GEARHEADS

### DIMENSIONS

K6IS6N□

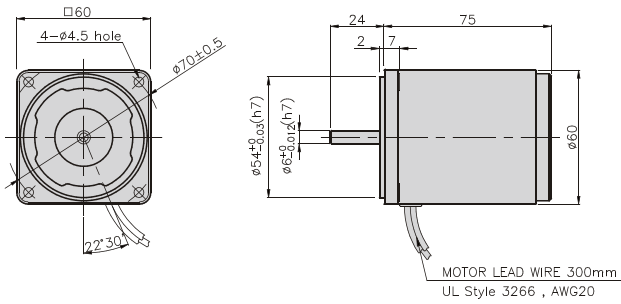

K6IS6N□-T

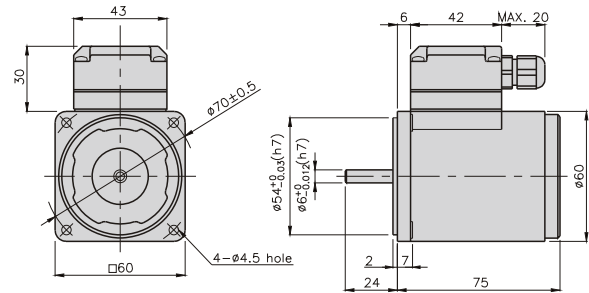

### CONNECTION DIAGRAMS

K6IS6N□

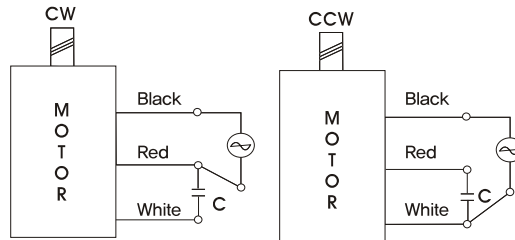

The direction of motor rotation is as viewed from the front shaft end of the motor

K6IS6N□-T

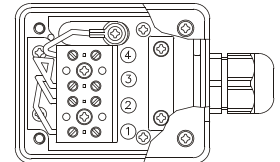
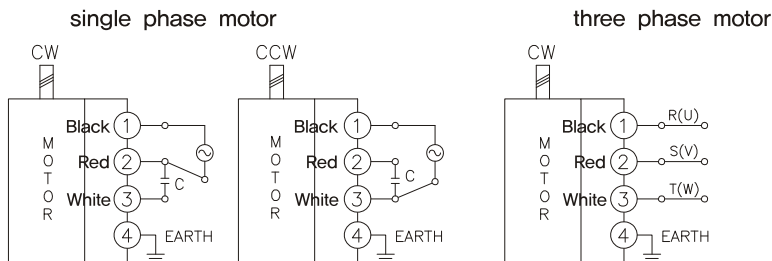

The direction of motor rotation is as viewed from the front shaft end of the motor

### DIMENSIONS

K6G□B(C)



DECIMAL GEARHEAD

K6G10BX□

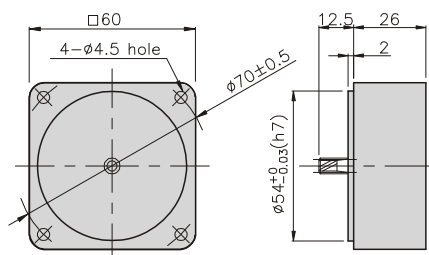

GEARHEAD

K6G□B(C)

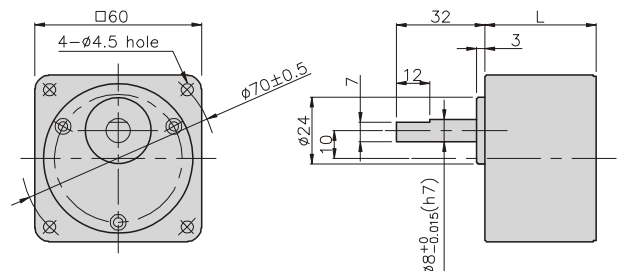

## GEARHEADS

### DIMENSIONS

K6IG6N□ + K6G□B(C)



K6IG6N□-T + K6G□B(C)



K6IG6N□ + K6G□B(C)

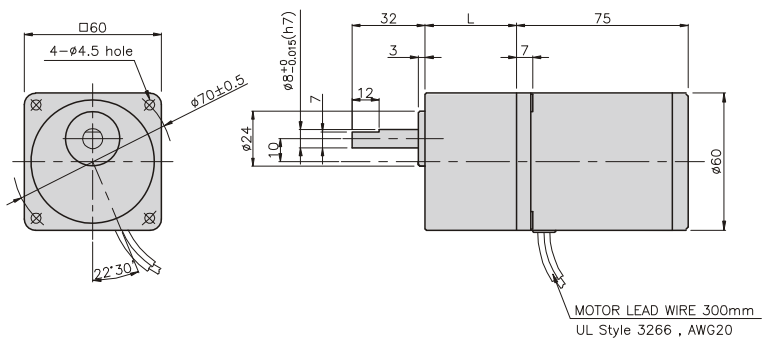

DIMENSION TABLE

PART No	L	Application Model	Mounting BOLT
01	30	K6G3~18B(C)	M4 P0,7 X 50
02	40	K6G20~250B(C)	M4 P0,7 X 60
03	26	K6G10BX	M4 P0,7 X 85

WEIGHT

PART	WEIGHT(kg)	
MOTOR	0,72	
DECIMAL GEAR HEAD	0,22	
GEAR HEAD	K6G3~18B(C)	0,26
	K6G20~40B(C)	0,33
	K6G50~250B(C)	0,36

K6IG6N□-T + K6G□B(C)

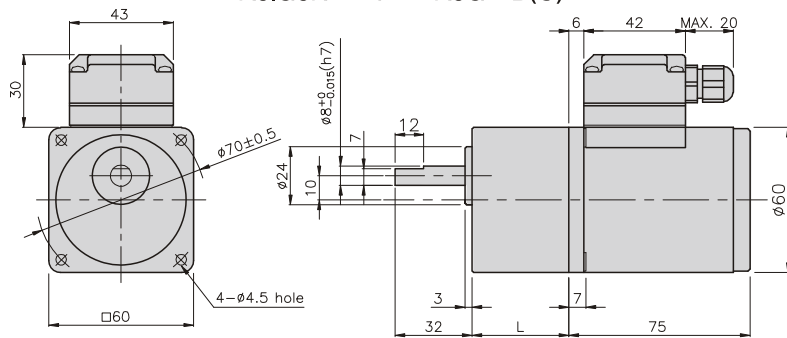

DIMENSION TABLE

PART No	L	Application Model	Mounting BOLT
01	30	K6G3~18B(C)	M4 P0,7 X 50
02	40	K6G20~250B(C)	M4 P0,7 X 60
03	26	K6G10BX	M4 P0,7 X 85

WEIGHT

PART	WEIGHT(kg)	
MOTOR	0,76	
DECIMAL GEAR HEAD	0,22	
GEAR HEAD	K6G3~18B(C)	0,26
	K6G20~40B(C)	0,33
	K6G50~250B(C)	0,36